

# Wheel lock Screws

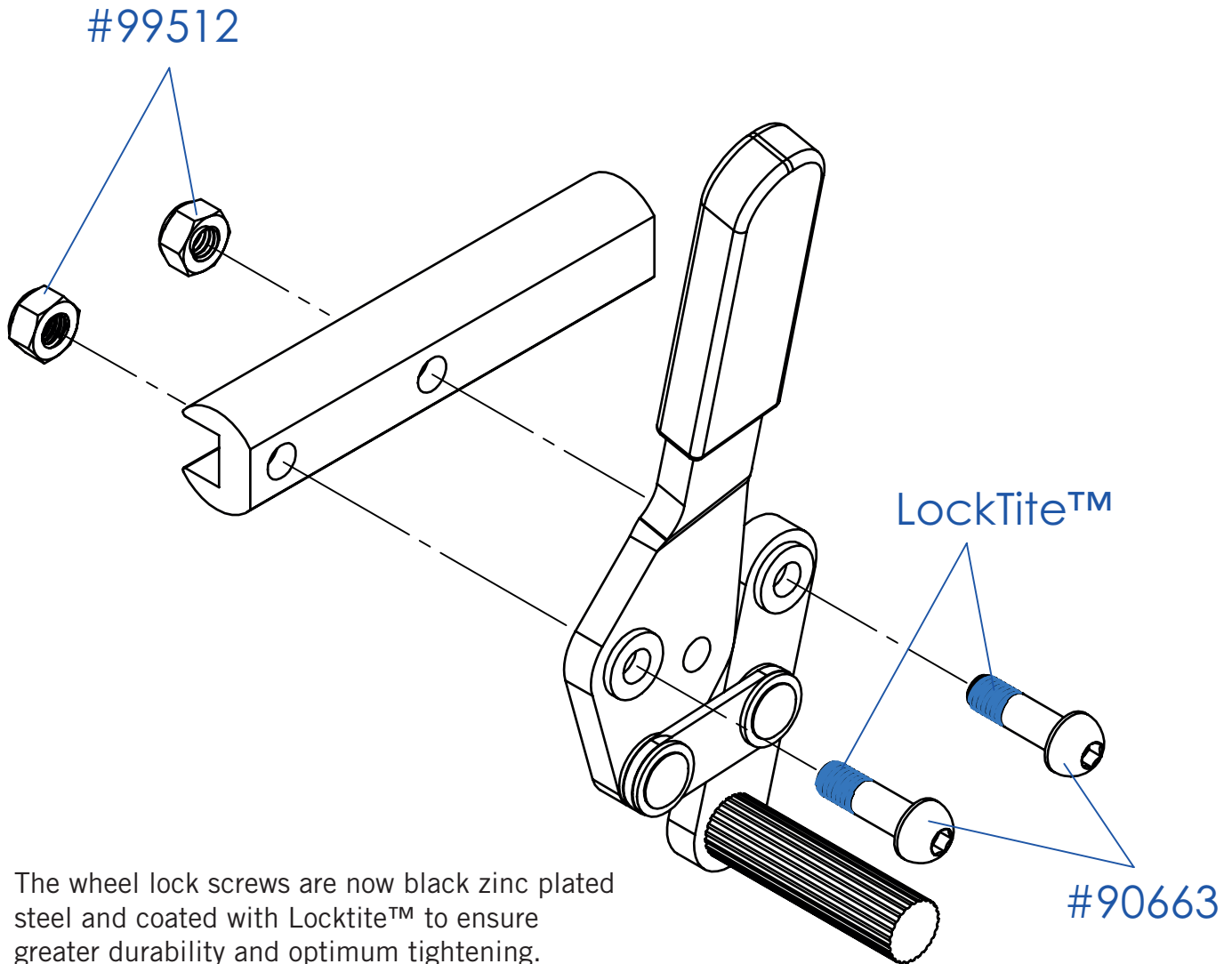

The wheel lock screws are now black zinc plated steel and coated with Locktite™ to ensure greater durability and optimum tightening.

A pair of wheel locks will need 4 screws (90663) and 4 nuts (99512)