



## INSTRUCTION SHEET

# OXYGEN TANK HOLDER INSTALLATION (HELIO A6 – HELIO A7 – HELIO C2 - MOVE)



- The oxygen tank holder is incompatible with the ISO 7176-19 option.



- Before the beginning of the installation, make sure to have all needed pieces. The pieces must be ordered by your representative or by the customer service from Motion Composites. Have your serial number on hand to facilitate the order.

### Material(s) required:

- Oxygen tank holder (#0060501B-00)

### Tool(s) required:

- 4 mm Allen key
- Thread locker
- 7 Nm adjusted torque wrench

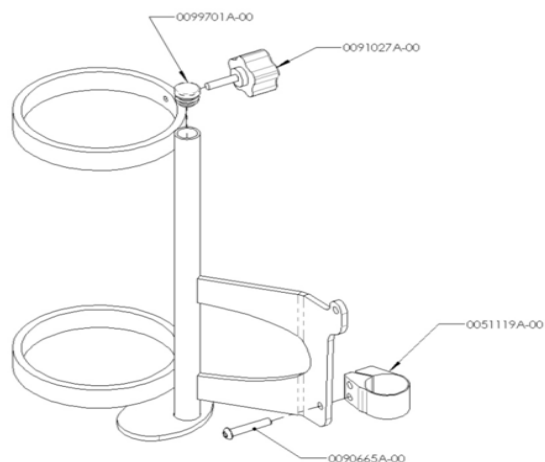

## LOWER PART HOLDER INSTALLATION

1. Take off the rear left wheel.
2. Install the clamp (#51119) onto the rear left frame of the wheelchair. (Figure 1)
3. Once installed, turn the clamp to get the final position. (Figure 2)

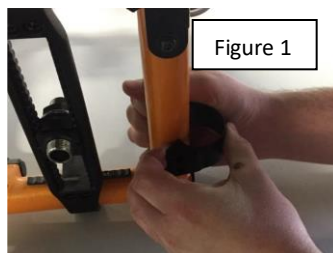

Figure 1

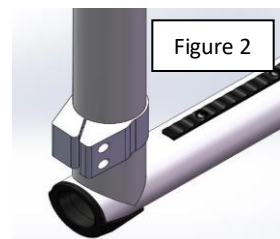

Figure 2



## INSTRUCTION SHEET

# OXYGEN TANK HOLDER INSTALLATION (HELIO A6 – HELIO A7 – HELIO C2 - MOVE)

4. Put 1 drop of thread locker on the tip of the screw (#0090665A-00).
5. Install lower part of the oxygen tank holder by inserting screw (#0090665A-00) into the clamp with the 4 mm Allen key (Figure 3).
6. Finalize the installation with the 7 Nm adjusted torque wrench.

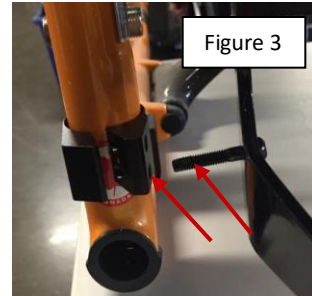

## UPPER PART HOLDER INSTALLATION

### CONFIGURATION 1:

- With flip-back + tie down (#9001233) – aluminium frame
- With flip-back only (#9001175) – aluminium frame
- With tie down only (#9001173) – aluminium frame
- Without flip-back + without tie down (#9001174) – aluminium frame
- With tie down only (9001235) – carbon frame

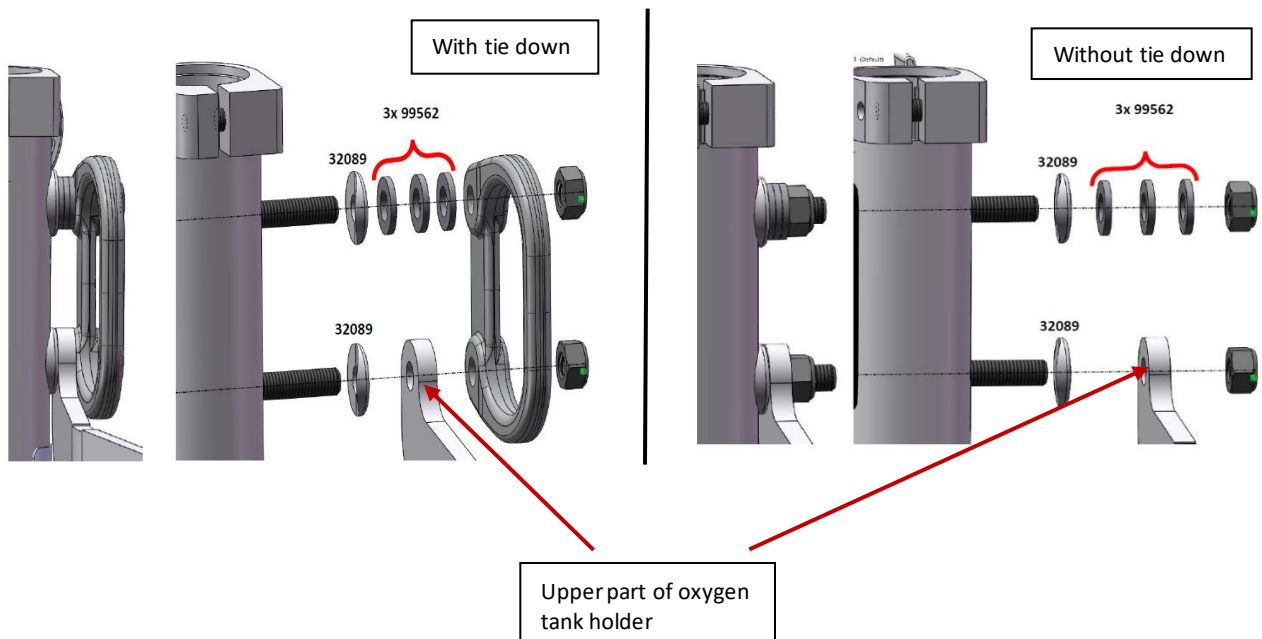



INSTRUCTION SHEET

**OXYGEN TANK HOLDER INSTALLATION  
(HELIO A6 – HELIO A7 – HELIO C2 - MOVE)**

1. Remove the spacer (#32066) behind the wheelchair.

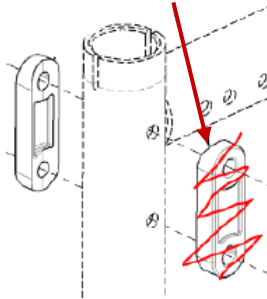

2. Add 1 X the spacer (#32089) on the top screw and on the bottom screw.
3. Add number of spacer (#32089) required depending on the wheelchair configuration to have a total of 3.

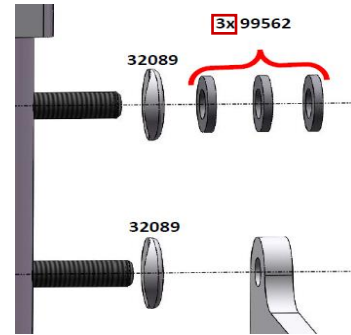

4. Put 1 drop of thread locker on the tip of each screw and finalize the installation with the 7 Nm adjusted torque wrench.

**CONFIGURATION 2:**

- With flip back only (#9001234) – carbon frame

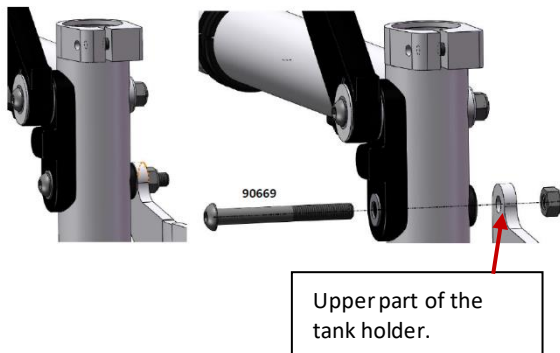

1. Replace the screw (#90667) by the longer screw (#90669).
2. Put 1 drop of thread locker on the tip of the screw and finalize the installation with the 7 Nm adjusted torque wrench.

**CONFIGURATION 3:**

- Without flip-back + without tiedown (#9001236) – carbon frame

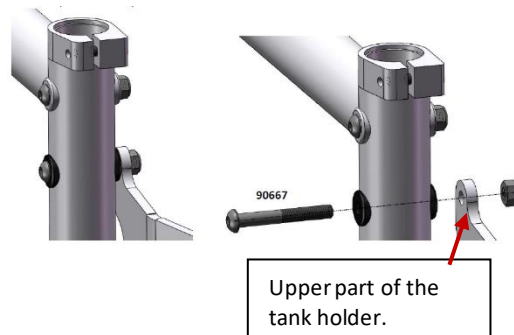

1. Replace the screw (#90666) by the longer screw (#90667).
2. Put 1 drop of thread locker on the tip of the screw and finalize the installation with the 7 Nm adjusted torque wrench.