





INSTRUCTION SHEET

**CANE/CRUTCH HOLDER INSTALLATION FOR RIGID AND FOLDING WHEELCHAIRS**

-  • The cane and crutch holder should never be used as a tipping lever. Doing so could result in damage to the wheelchair and/or injury to the user or caregiver.
-  • It is compatible with Motion Composites anti-tippers on both sides.
-  • It can be installed on the right or on the left but requires a different set of parts depending on the desired side.
- Before beginning assembly, make sure you have all the necessary parts. These parts must be ordered through your representative or through the Motion Composites customer service. Make sure to have the serial number of your wheelchair to make ordering easier.

**Material(s) required:**

- Rigid wheelchairs set APEX A-APEX C (#0004040A)
- Folding wheelchairs set HELIO A6-HELIO A7-HELIO C2-MOVE-VELOCE (#9001627-9001628)

**Tool(s) required:**

- 5 mm Allen key
- Thread locker
- 12 Nm adjusted torque wrench

**FOR THE RIGID WHEELCHAIRS**

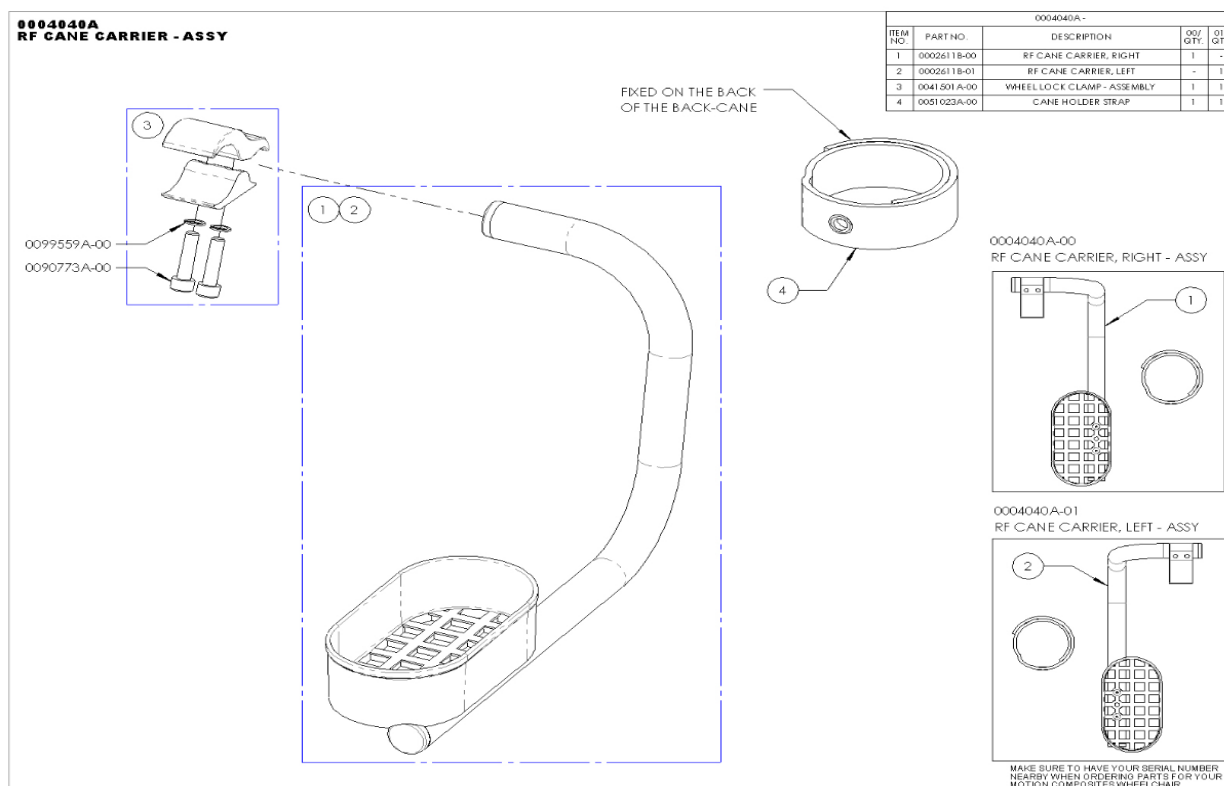



## INSTRUCTION SHEET

# CANE/CRUTCH HOLDER INSTALLATION FOR RIGID AND FOLDING WHEELCHAIRS

### Installation of the cane/crutch holder basket

1. Insert the tube of the cane/crutch holder into the opening of the clamp and position the clamp on the rear camber tube.

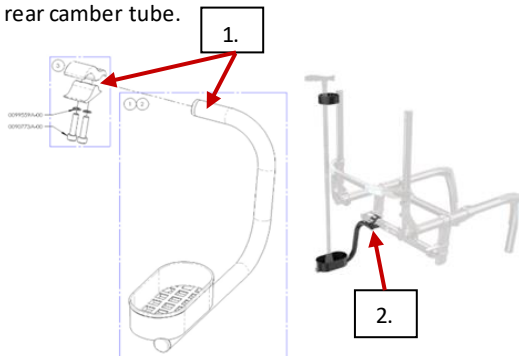

2. Put 1 drop of thread locker on the tip of both screws and insert the screws and lock washers into the clamp and tighten slightly.
3. Adjust the clamp position on the camber tube to the desired position.
4. Turn the clamp on the camber tube to adjust the height of the cane holder to the ground.
  - It should be higher than the anti-tippers, if any, and the bottom of the cane holder basket should be parallel to the ground when adjustments are complete.
5. Finalize the installation with the 12 Nm adjusted torque wrench.

### Installation of the cane/crutch holder Velcro strap

1. Unscrew the screw from the push handle or backrest cover retainer on the desired side.

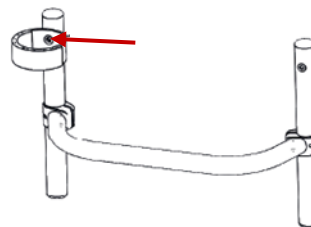

2. Put 1 drop of thread locker on the tip of the screw and install the screw through the Velcro strap to secure it in place.

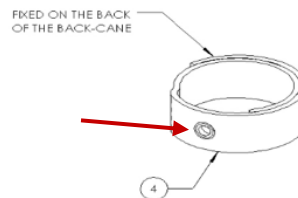



INSTRUCTION SHEET

CANE/CRUTCH HOLDER INSTALLATION FOR RIGID AND FOLDING WHEELCHAIRS

**FOR THE FOLDING WHEELCHAIRS**

**9001627\_9001628 Cane Holders**

ITEM NO.	PARTNO	DESCRIPTION	9001628 QTY.	9001627 QTY.
1	51905	CANE HOLDER RIGHT - ASSEMBLY	-	1
2	51906	CANE HOLDER LEFT - ASSEMBLY	1	-
3	41601	BRAKE CLAMP	1	1
4	51023	CANE HOLDER STRAP	1	1

FIXED ON THE BACK OF THE BACK-CANE

90773  
99559

99701

99701

9001628 - Cane Holder - Left

MAKE SURE TO HAVE YOUR SERIAL NUMBER NEARBY WHEN ORDERING PARTS FOR YOUR MOTION COMPOSITES WHEELCHAIR

**Installation of the cane/crutch holder basket**

1. Put the plugs (#99701) on both sides + insert the tube of the cane/crutch holder into the opening of the clamp.

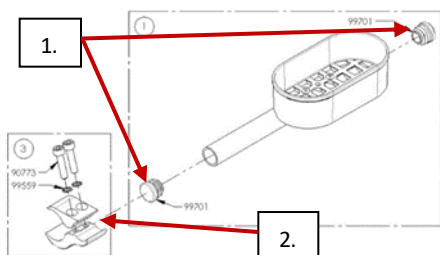

2. Turn the clamp on the camber tube to adjust the height of the cane holder to the ground.
  - It should be higher than the anti-tippers, if any, and the bottom of the cane holder basket should be parallel to the ground when adjustments are complete.
3. Finalize the installation with the 12 Nm adjusted torque wrench.

**Installation of the cane/crutch holder Velcro strap**

1. Unscrew the screw from the push handle or backrest cover retainer on the desired side.

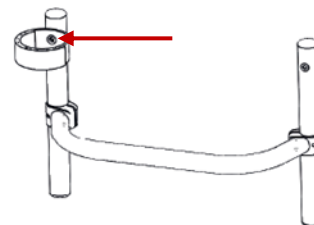

2. Put 1 drop of thread locker on the tip of the screw and install the screw through the Velcro strap to secure it in place.

