



MANUAL
WHEELCHAIRS

NEW AND IMPROVED 2022

INTRODUCING NEW AND IMPROVED FEATURES ON ALL OUR WHEELCHAIRS

As always, Motion Composites is committed to provide meaningful and enhanced experiences for our wheelchair users. Our desire to constantly improve our products is driven by the feedback we received from our customers. As a result, we reviewed our whole lineup of wheelchairs and we are introducing several improvements and new accessories. In addition to improving the user experience, these new features are additional tools that will allow you to adequately meet the needs of your customers. We invite you to discover them over the following pages.

For any question or additional information, please contact your local representative or our Customer Service at **1 888 650-6555** or by email at **info@motioncomposites.com**



TABLE OF CONTENTS



04

FRONT WHEEL
ASSEMBLY

05

BACK CANES

06

ARMRESTS

09

ACCESSORIES

10

WHEEL LOCKS

11

PRIMARY
STRUCTURE

12

WC-19

13

OCCUPIED
TRANSIT
ANCHOR KITS

FRONT WHEEL ASSEMBLY

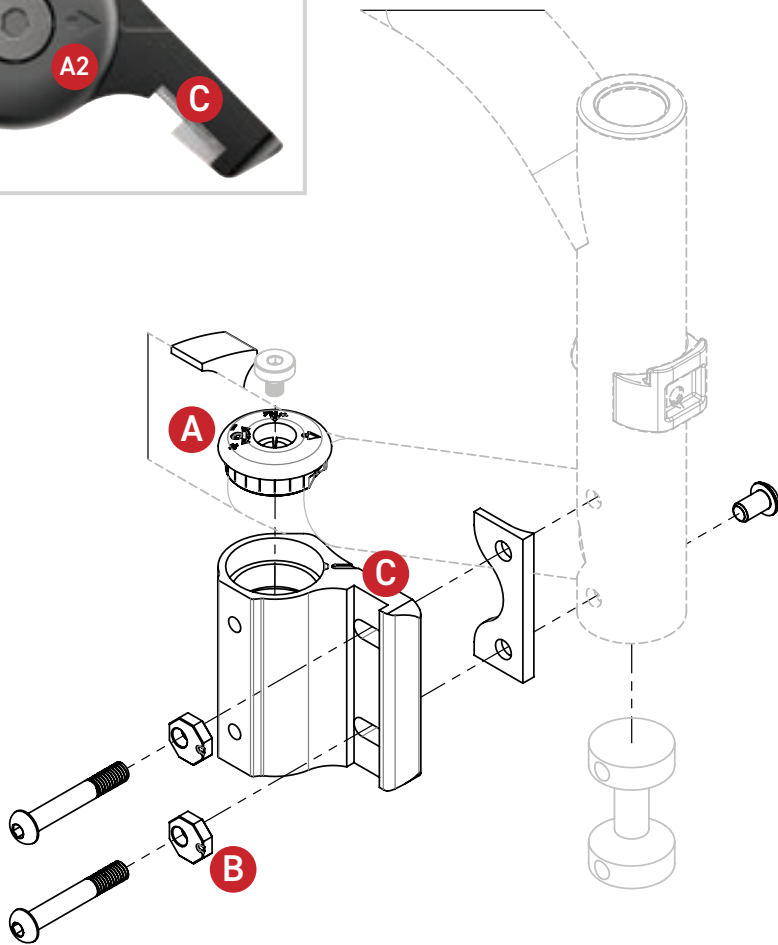

CASTER HOUSING

HELIO A6 | MOVE

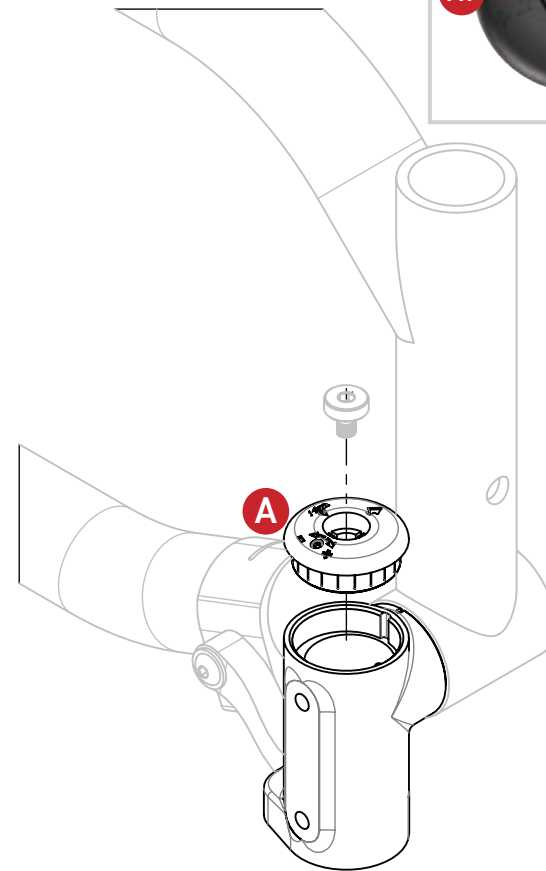

CASTER HOUSING EVOLVE

HELIO C2 | HELIO A7 | HELIO kids

A CASTER ANTI-FLUTTER CAP **IMPROVED**

*HELIO C2 | HELIO A7 | HELIO A6
MOVE | HELIO kids*

- New material
- A1** • New caster flutter adjustment screw position for a more precise and durable setting
- A2** • New marking for easier installation
- New stem bolt torque marking

- **INCREASED DURABILITY**
- **EASIER TO HANDLE AND INSTALL**
- **SMOOTHER AND QUIETER FUNCTIONING**

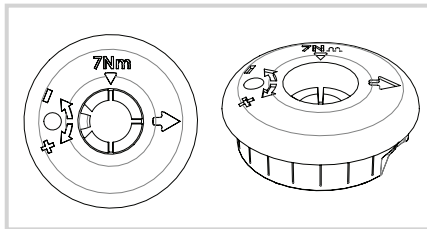

B ECCENTRIC WASHER **IMPROVED**

HELIO A6 | MOVE

- New material

- **INCREASED DURABILITY**

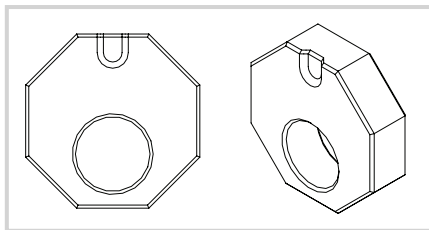

C CASTER HOUSING **IMPROVED**

HELIO A6 | MOVE

- Deeper groove on the caster housing for increase support of the eccentric washer
- New screw design to support the caster housing to increase durability

- **INCREASED DURABILITY AND STABILITY**

BACK CANES

HEIGHT ADJUSTABLE BACK CANES 21-24"

NEW

HELIO A7 | HELIO A6 | MOVE

- New dimensions added to our existing range
- Available in straight or 8 degrees version
- Available in aluminum only
- Integrated handles
- Adjustable in 1 inch increments
- Available only with fixed angle back cane

- **IMPROVED WHEELCHAIR PUSHING ERGONOMICS FOR CAREGIVERS**

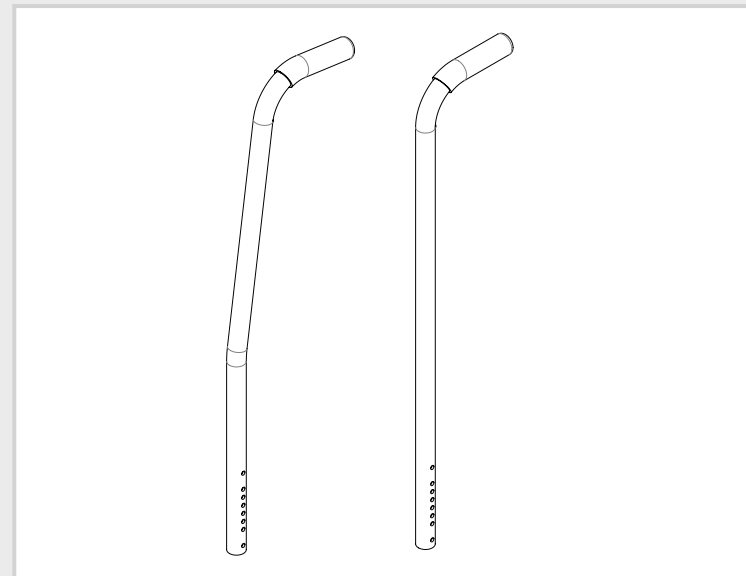

ARMRESTS



"T" ARMREST 6-10" **NEW**

APEX C | APEX A | VELOCE | HELIO C2 | HELIO *A*
HELIO *A6* | MOVE | HELIO *kids*

- Full length and desk length versions available

- NEW SHORTER MODEL ADDED TO OUR EXISTING MODELS TO REACH A LARGER RANGE OF ANATOMICAL MEASUREMENTS
- AN ARMREST ADAPTED TO THE USER'S HEIGHT OFFERS BETTER SUPPORT TO UPPER LIMBS AND ALLOWS FOR OPTIMAL POSITIONING

ARMREST RECEIVER **IMPROVED** **COMING SOON**

APEX C | APEX A | VELOCE | HELIO C2
HELIO *A* | HELIO *kids*

- New assembly and improved method of adjustment
- Modification to design for a stronger connection between the armrest and the receiver

- EASIER TO INSTALL AND ADJUST
- LESS LIKELY TO DAMAGE THE PAINTED FRAME

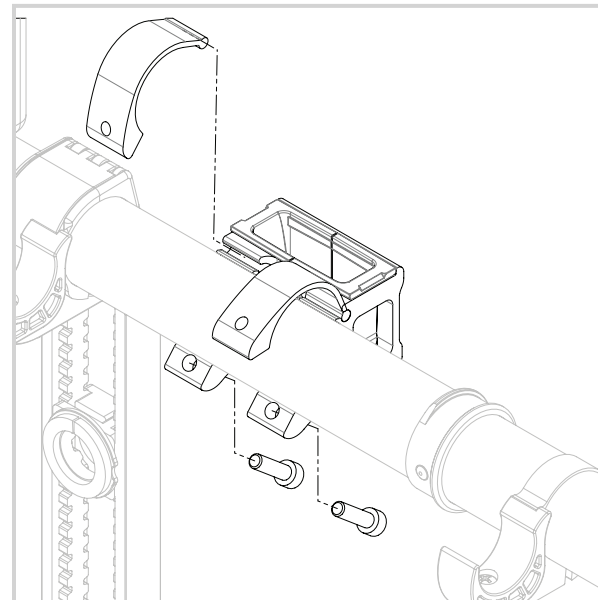

"T" AND "FLIP BACK" ARMREST LOCKING SYSTEM

IMPROVED

- Change in the design for a stronger connection between the armrest and the receiver
- Prevents unintended armrest release

FLIP BACK ARMREST

VELOCE | HELIO C2 | HELIO A7 | HELIO A6

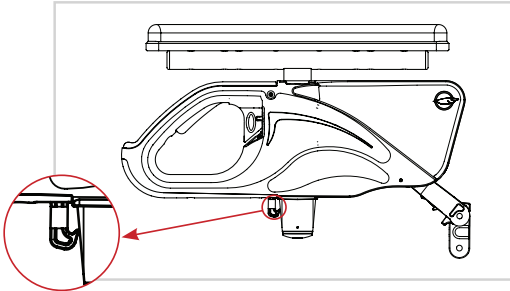

"T" ARMREST

APEX C | APEX A | VELOCE | HELIO C2
HELIO A7

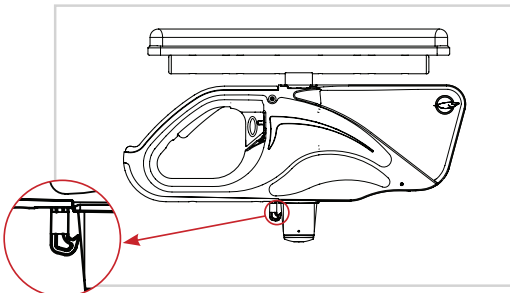

"T" ARMREST HELIO A6

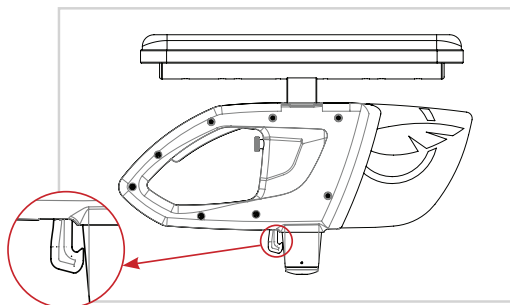

"T" AND "FLIP BACK" ARMRESTS STRUCTURE

IMPROVED

APEX C | APEX A | VELOCE | HELIO C2

HELIO A7 | HELIO A6 | MOVE | HELIO kids

- Addition of a second series of holes allowing to install the armrest

- **ALLOWS FOR A WIDER RANGE OF ARMREST CONFIGURATIONS TO MEET POSITIONING AND FUNCTIONAL REQUIREMENTS**



FULL LENGTH SWING AWAY ARMREST **NEW**

APEX C | APEX A | VELOCE | HELIO C2 | HELIO A7 | HELIO A6 | MOVE | HELIO kids

- A full length version of our swing away armrest

- NEW LONGER MODEL ADDED TO OUR EXISTING RANGE
- AN ARMREST ADAPTED TO THE USER'S CONDITION OFFERS A BETTER SUPPORT TO UPPER LIMBS AND ALLOWS FOR OPTIMAL POSITIONING



RIGID



FOLDING

ACCESSORIES

APEX CANE AND CRUTCH HOLDER **NEW**

APEX C | APEX A

- Addition to the existing range of APEX accessories
- Can be installed on the left or the right side of the chair

- **ALLOWS TRANSPORT OF A MOBILITY AID ON A RIGID FRAME**



PELVIC POSITIONING BELT **IMPROVED**

APEX C | APEX A | VELOCE | HELIO C2

HELIO A7 | HELIO A6 | MOVE | HELIO kids

- Adjustment rings on both side of the belt buckle.

- **ALLOWS TO PLACE THE BELT BUCKLE IN THE DESIRED LOCATION FOR OPTIMAL POSITIONING AND FUNCTION**



WHEEL LOCKS

UNILATERAL WHEEL LOCK **NEW**

VELOCE | HELIO C2 | HELIO A7 | HELIO A6
MOVE | HELIO kids

- Allows for bilateral locking of the rear wheels while being operated with only one hand
- Double cable design for smoother operation
- Can be installed on the left or the right of the chair
- Ideal for users with the following health conditions:
 - Hemiplegia
 - Hemiparesis
 - Amputation
 - Hemianopsia

- **ALLOWS US TO OFFER A WHEEL LOCK SYSTEM TO SOMEONE WHO USES ONLY A SINGLE UPPER LIMB**
- **IDEAL COMBINATION WITH THE ONE ARM DRIVE**
- **EASY TO ADJUST**



NEWTON WHEEL LOCK - PUSH TO LOCK

IMPROVED

APEX C | APEX A | VELOCE | HELIO C2
HELIO A7 | HELIO A6 | MOVE | HELIO kids

- New material, 30%* stronger than previous generation
- Longer wheel lock rail comes standard to allow for more configurations
- Smooth and rounded wheel lock tip for more comfort and protection

- INCREASED DURABILITY AND STABILITY
- PROVIDES THE PERFORMANCE OF ALUMINIUM WHEEL LOCKS, BUT LIGHTER

*Results based on an ultimate strength comparative test developed by Motion Composites.



PRIMARY STRUCTURE



HELIO A7 & A6 SYMMETRICAL HYDROFORMED CROSS BRACE AND FRAME

IMPROVED

HELIO A7 | HELIO A6 | MOVE

- Modification of the central pivot design and improved support of cross brace on the frame

- INCREASED DURABILITY AND RIGIDITY FOR MORE EFFICIENT PROPULSION

WC-19 TRANSIT TIE DOWN WITHOUT BELT

NEW

APEX C | APEX A | VELOCE | HELIO C2
HELIO A7 | HELIO A6 | MOVE | HELIO kids

- Our WC-19 transit kit is now offered without a seatbelt
- Seat belt sold separately
- Two versions available: folding and rigid
- Now compatible with the depth adjustable back on the APEX



WC-19

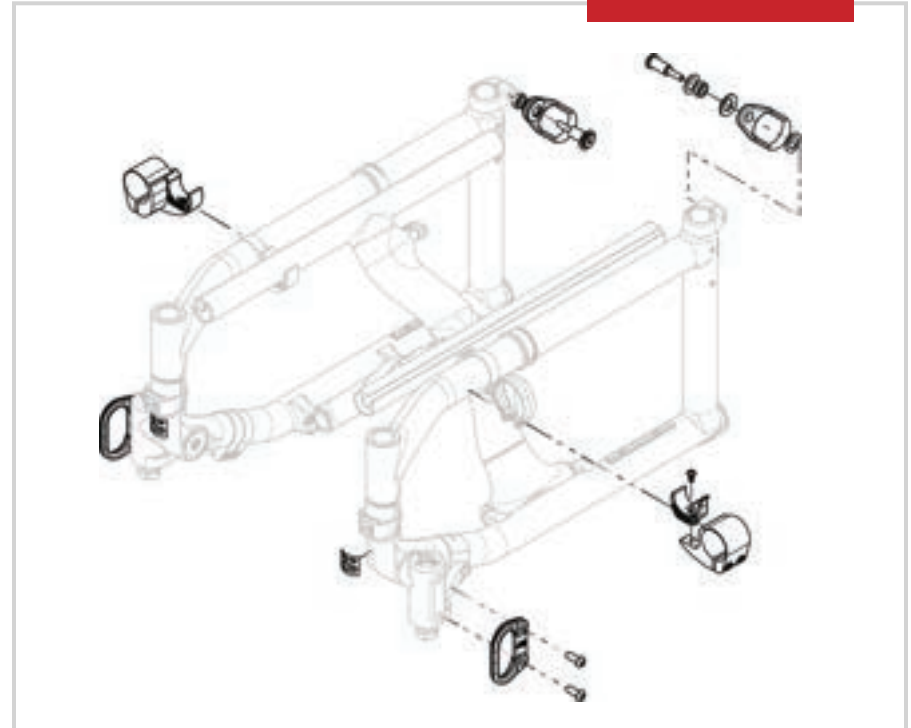

OCCUPIED TRANSIT ANCHOR KITS

- The Motion Composites wheelchairs equipped with an optional occupied transit anchor kit are designed to be secured facing forward then used in a motor vehicle in compliance with RESNA WC-4:2017, Section 19 or ISO 7176-19:2019.
- The occupied transit anchor kits are designed and tested to be used exclusively with four-point strap-type tiedown systems.
- The wheelchair size and turning radius can significantly affect accessibility to, and maneuverability in motor vehicles. Smaller wheelchair with a shorter turning radius will generally provide greater ease of access to a forward-facing position in a motor vehicle.
- In some markets, Motion Composites occupied transit anchor kits can be equipped and has been tested with a wheelchair anchored pelvic safety belt.
 - The wheelchair anchored pelvic safety belt can be used with a vehicle anchored chest safety belt with a standard lower anchorage connector for effective crashworthy three-point-belt restraint in a motor vehicle.
 - Always use this optional belt with the vehicle anchored chest safety belt.
 - The optional wheelchair anchored is only available for purchase from Motion Composites and only available as a Motion Composites factory-installed option.
 - If this option is not present, always use the vehicle anchored three-point-safety-belt. NEVER rely on a positioning belt during occupied transit.
- Alterations or substitutions should not be made to the wheelchair anchor points or to parts or components of the wheelchair or seating system structural members. Any significant alteration or substitution to the wheelchair's components or seating could significantly alter the chair's performance during an impact.
- Motion Composites expressly disclaims that use of its occupied transit anchor kit option on a Motion Composites wheelchair will prevent the wheelchair user from injury or death in the event of a motor vehicle accident.
- Any installation or modification of an occupied transit anchor kit after sale must be made at the Motion Composites factory.

TEST CONFIGURATION (FOLDING CHAIRS)

Seat Width.....	18 in
Seat Depth.....	18 in
Seat Back Height.....	18 in
Front Seat-to-Floor Height.....	18 in
Rear Seat-to-Floor Height.....	16.75 in
Seat Angle.....	4 degrees
Seat Back Angle.....	10 degrees
Wheelchair Weight	HELIO C2 – 31 lb
	HELIO A7 – 35 lb
	HELIO A6 – 35 lb
	VELOCE – 31 lb
	MOVE – 37 lb
	+/- 0,5 lb
Seat Upholstery.....	Adjustable Tension
Backrest.....	Soft Nylon
Backrest Canes.....	Adjustable Height 18-21 in
Footrest Angle.....	90 degrees
Rear Wheels.....	24 in. spoke wheels with 0 degrees of camber
Rear Tire.....	Soft Urethane of 24 x 1.25 in
Caster.....	6 in with Polyurethane tire on a 3-spoke composite wheel
Angle Footplate.....	Fixed composite
Other Options.....	None
Mass of ATD Dummy.....	172 lb
Maximum User Weight.....	265 lb

OCCUPIED TRANSIT ANCHOR KITS

TEST CONFIGURATION (RIGID CHAIRS)

Seat Width.....	18 in
Seat Depth.....	18 in
Seat Back height	18 in
Front Seat-to-Floor Height.....	18 in
Rear Seat-to-Floor Height.....	15 ½ in
Seat Angle.....	.4 degrees
Seat Back Angle.....	10 degrees
Wheelchair Weight.....	APEX C – 29 lb, APEX A – 30 lb
Seat Upholstery.....	Soft
Backrest.....	Adjustable Tension
Backrest Canes.....	Adjustable Height 18-21 in
Front Frame Angle	110 degrees
Rear Wheels.....	24 in. spoke wheels with 0 degrees of camber
Rear Tire.....	Soft Urethane of 24 x 1.25 in
Caster.....	.6 in with polyurethane tire on a 3-spoke composite wheel
Angle Footplate.....	Angle Adjustable
Other Options.....	None
Mass of ATD Dummy.....	172 lb
Maximum User Weight.....	265 lb

Rating for ease of properly positioning a belt restraint, as tested for ISO 7176-19:2019:

- HELIO C2: Poor
- HELIO A7, A6: Good
- APEX A: Good
- APEX C: Poor

Rating for the proper belt restraint positioning, as tested for ISO 7176-19:2019:

- HELIO C2, A7, A6: Excellent
- APEX C, A: Excellent

Motion Composites have been tested and comply to RESNA WC4:2017, Section 19 in accordance with crash test requirements only.

Refer to the user manual for complete warnings and details.

GO BEYOND!

Who we are: passionate innovators pushing the boundaries of what is possible. What we do: combine leading-edge engineering with innovative materials to create movement. What makes us proud: having our ultralight wheelchairs echo the love of life their users demonstrate each day.

Through our unique approach and distinct attitude, our aim is to enhance lives, nourish a sense of freedom and revolutionize the way people see wheelchairs.

LEARN MORE To learn and find more information regarding our products, options and accessories, visit our website at motioncomposites.com



T 1 866 650-6555

F 1 888 966-6555

motioncomposites.com

NEW AND IMPROVED 2022